

Decks

Contents

Decks	1
Timing & Prerequisites	3
Materials Needed	4
Deck Building Activities (New Build & Additions).....	5
Organize Lumber and Joist.....	5
Sill Plates (1 st Floor Only)	6
Verify the Foundation Size	6
Lay Out the Sill Plates	7
Cut and Drill the Sill Plates.....	7
Install the Sill Sealer.....	8
Install the Sill Plates	9
Floor Joists	11
Floor Joist System Components	11
Triforce Open Web Joist Design	12
Floor Joists Installation	14
Review the Floor Joist Engineering Documents.....	14
Layout the Floor Joists	15
Correct the bolt layout. (1 st Floor Only)	17
Install the Floor Joists and LVLs	17
Stairway Opening Framing (1 st Floor Only)	22
Construct the Bearing Wall.....	22
Install Parallel Joist Blocking.....	24
Strong-backs	27
Install the Strong-backs.....	27
Install Type X Fire-Rated Drywall (1st Floor Deck only).....	29
Install the Rim Joists (Band Board).....	29
Post King/Jacks to the Sill/Top Plate	31
Mounting board for Water Manifold.....	31
Decking	32
Setup Fall Protection.....	32
Lay out the Decking	32
Install the Decking.....	33
Safety Activities	36

- Temporary Stairs (1st Floor Only)..... 36
 - Build Temporary Stairs for Accessing the Deck 36
- Guardrails 40
 - Install Guardrail Posts at Stairways..... 40
 - Install Guardrail Posts on Edge of the Deck..... 42
 - Install Guard Railings and Toe boards 42
- Hanging Wall Scaffolding System (2nd Floor Only)..... 43
 - Hanging Wall Scaffolding Systems 44
 - Hanging Wall Scaffolding Use and Timing 44
- Install Styrofoam Board behind Porch Concrete (1st Floor only).... 45
- Concrete Porch Caps (Contractor)..... 45
- Re-Install the Temporary Stairs after the Porch Cap is poured 45

This chapter will address building the 1st and 2nd floor decks since many of the components are common to both. Components which are not common will be marked as “1st floor deck” or “2nd floor deck”.

Things to Consider
<ul style="list-style-type: none"> ➤ It is important to start with a square deck and to the correct dimensions, as this will determine the dimensions of the structure above. ➤ When installing floor joists, ensure there are enough volunteers to safely handle them. ➤ When installing the decking, limit the number of volunteers working near the edge.
Safety Issues
<ul style="list-style-type: none"> ➤ No walking, standing or sitting on foundation walls. ➤ No leaning over the side of the walls.

Components		
Temporary Stairs		Sill Plates
Bearing Walls 1 st and 2 nd		
Floor Joist	Rim Joists	Decking
Guard Rails 2 nd floor only	Strong-backs	
Scaffolding Systems		

Timing & Prerequisites

First Floor Deck

- The first-floor deck cannot begin until:
 - The foundation has been poured.
 - The foundation has been back-filled.
 - The basement slab has been poured.
 - The Temporary Stairs have been installed.
- AEP should have connected the power to the temporary power pole. If they have not, a generator and fuel to run it will be needed.
- The House/Project Lead will work with the Construction Superintendent to coordinate these volunteer activities.

Second Floor Deck

- The second-floor deck cannot begin until the first floor exterior and interior walls and second top plates are complete.
- The House/Project Lead will work with the Construction Superintendent to coordinate these volunteer activities.

Materials Needed

<i>Tools Needed (See the “Framing Tools, Materials and Techniques” chapter)</i>	
<i>Materials Needed</i>	
Sill Plates	Bearing Wall
Pressure-Treated 2x8s Sill Sealer Double Dipped Galvanized Washers (#10) #10 Nuts 8d Hot Dipped Galvanized Nails Titan Bolts	2x4s for Studs and Top Plates Pressure-Treated 2x4s for Bottom Plate 16d Sinkers Nails 2 1/2” Tapcons or Ramset Nails 16d Hot Dipped Galvanized Nails
Floor Joists	Decking
Floor Joist 5/8” OSB 2x6s for Strong-Backs 1 3/4” LVL for Stair Headers 1 1/8” LSL Rim Joist Board Joist Hangers 16d Sinker Nails 16d Hot Dipped Galvanized Nails 8d Hot Dipped Galvanized Nails 10d Sinker Nails N10 Hanger Nails Spray Paint	3/4” Tongue-in-groove OSB Miscellaneous Plywood Miscellaneous 2x4s Construction Adhesive 8d Spiral Shank Galvanized Deck Nails 2-3/8 in x .113 in framing nails Styrofoam Board
Temporary Stairs	Guardrails
2x12s for Stringers 2x10s for Treads 2x8 for bottom plate 2 1/2” exterior screws 1” wide Metal Strapping 2x4s for posts and railings Support Brackets 3/8”x4” carriage bolts and nuts Shingles 1 1/2” roofing nails	2x4s for posts and railings 2 1/2” exterior screws
Fire-Rated Walls	Scaffold Systems
5/8” Exterior Gypsum Board	See Manufactures Documentation

Deck Building Activities (New Build & Additions)

Organize Lumber and Joist

Critical Issues
➤ Keep lumber flat, dry and covered to prevent warping.
Safety Issues
➤ Building materials must be stored at least 6' from the house.

- 1. Store the Floor Joist.**

Set up a flat area for delivery and storage of the floor joists. Floor joists must be stored on a fairly flat area. Add blocking under the floor joists if necessary.
- 2. Organize and Store the Framing Lumber**

Based on the cut sheets provided by the Construction Superintendent or packing slip, separate the lumber into stacks of:

 - Pressure-treated 2X8's for the sill plates
 - 5/4 Laminated Strand Lumber (LSL) for rim joists
 - 1 3/4" Laminated Veneer Lumber (LVL) for headers
 - SPF 2x4s and Pressure-Treated 2x4s for the basement walls, temporary stairs, and guardrails
 - 2x6s for floor joist strong-backs
 - 2x10s for stair treads
 - 2x12s for stair stringers
 - 4x8 sheets of 3/4" OSB decking
- 3. Remove unusable lumber**

As the linear lumber is sorted, look for severely cupped, bowed, or twisted lumber. Set these pieces aside and report them to the Construction Superintendent.
- 4. Count materials received**

Count and verify the lumber and joists received to the packing slip. Separate the joists into groups as identified on the joist plan. Ensure the correct number and size of each has been received. Notify the Construction Superintendent immediately if joists are missing.

Sill Plates (1st Floor Only)

Critical Issues

- Pressure-treated lumber must be used.
- The outside dimensions of the sill plates must match the building plans less 1" (the width of the OSB sheathing, 1/2" on each side of the house).
- Each board must be secured by at least 2 bolts; there must be a bolt every 8' of the board; and there must be a bolt within 12" of each end of the board.
- The corners must be square.
- Anchor bolts must be tightened securely.
- The sill plate must be drilled to fit over the electrical bonding/grounding rebar stub up.

Safety Issues

- Working around the open foundation is a hazard.
- Do not lean over the foundation wall.

Pressure treated 2x8s are anchored to the foundation walls to provide a base for building the house. The 2x8s are attached with J-bolts installed in the foundation walls and secured with washers and nuts.

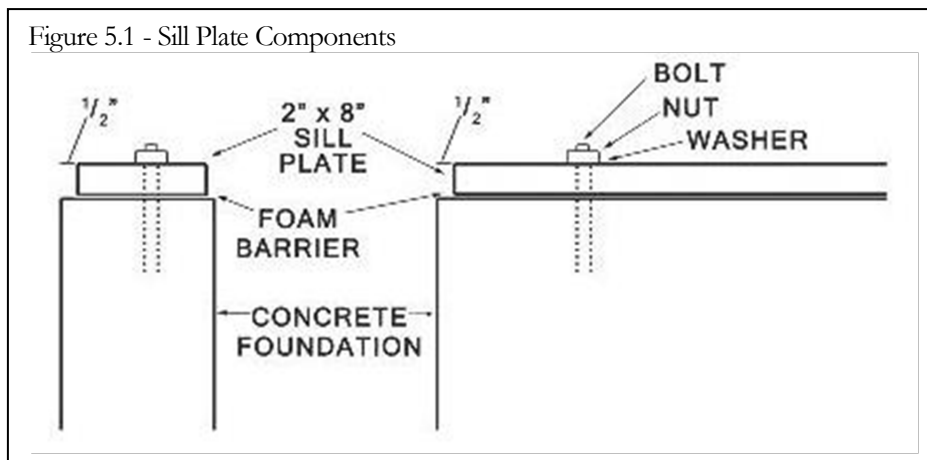

Verify the Foundation Size

Before installing the sill plates, measure the width, length and diagonal dimensions of the foundation and verify the measurements to the foundation plans.

- Verify the length of each wall to the length identified in the building plans. If the lengths differ by more than 1", notify the Construction Superintendent.
- Check the width of the foundation at various points to ensure it matches the building plans.

Lay Out the Sill Plates

The sill plates must be laid out carefully. These will form the foundation of the house.

- The sill plates will be installed roughly 1/2" from the exterior of the foundation to allow room for the exterior oriented strand board (OSB) sheathing.
- Using the Sill Plate Layout drawing, place the 2x8s in the proper position. The correct lengths of lumber must be used to ensure the ends of the board fall within 12" of an anchor bolt.

Cut and Drill the Sill Plates

Critical Issues

- **Each section of sill plate must be bolted down in at least 2 places with:**
 - 1 bolt within 12" of each end
 - 1 bolt every 8'
- **The cup of the sill plate must be pointed up.**

1. Cut pressure-treated 2x8's per the Sill Plate Layout. The Sill Plate Layout has been calculated so each section of sill plate will cover at least 2 anchor bolts.
2. The sill plate will be installed 1/2" from the outside edge of the foundation.
3. If the 2x8 is cupped, it must be installed with the cupped (convex) side pointed up.
4. Drill holes for the anchors to pass through the sill plate. (See Figure 5.2).
 - Set the 2x8 on top of the foundation wall, outside of the foundation anchors.
 - Use a large square to mark a line on the board aligned with each side of the anchors.
 - Move the 2x8 to the inside of the foundation anchors.
 - Measure the distance from the outside of the foundation to the center of each anchor; then subtract 1/2".

- Use that distance to mark the center of the hole for the anchor on the sill plate.
 - Drill a 3/4" hole in the sill plate at the mark for the anchor to pass through.
5. An additional hole will need to be drilled in the section of sill plate which will fit over the rebar stub up which will be used for the electrical system bonding/grounding.

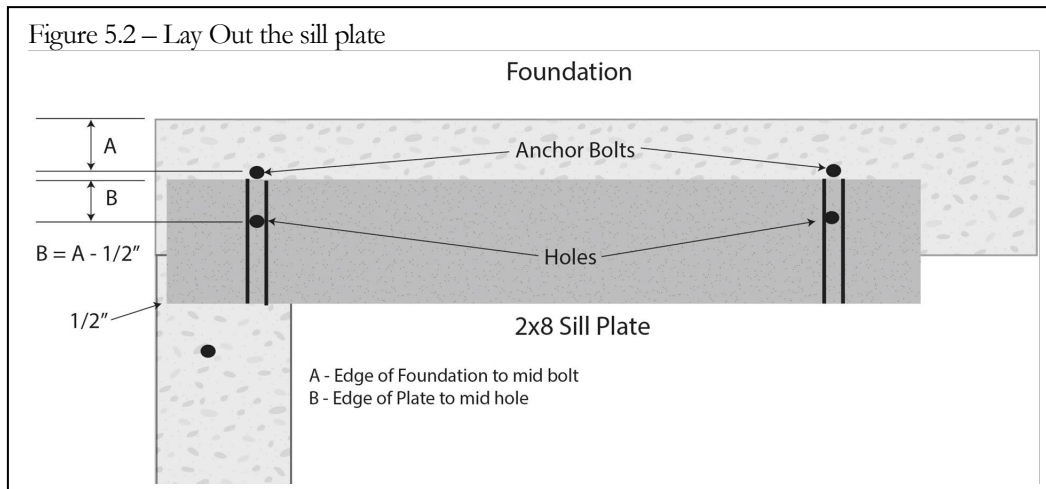

Install the Sill Sealer

Critical Issues

- ◆ The Sill Sealer provides the seal between the foundation and the sill plate to prevent air penetration. There should be **no gaps** in this seal.

1. Remove the nuts and washers from all the bolts around the perimeter of the foundation. Keep these all together; you will need them soon.
2. Roll out a layer of the Sill Sealer. (See Figure 5.3).
 - Begin at any point on the perimeter. Follow along the outer edge of the foundation wall. A piece of tape may be used to anchor the foam where you begin so the foam doesn't roll up behind you.
 - At the anchor bolts, cut a little hole in the foam and press the foam over the bolts and down to the concrete.
 - When joining 2 pieces of sill sealer, overlap the 2 pieces by 1"
 - At the corners, cut the insulation flush with the outside of the foundation.
 - Repeat on all sides of the foundation.
 - The foam must not end and begin at the same place as the sill plates.

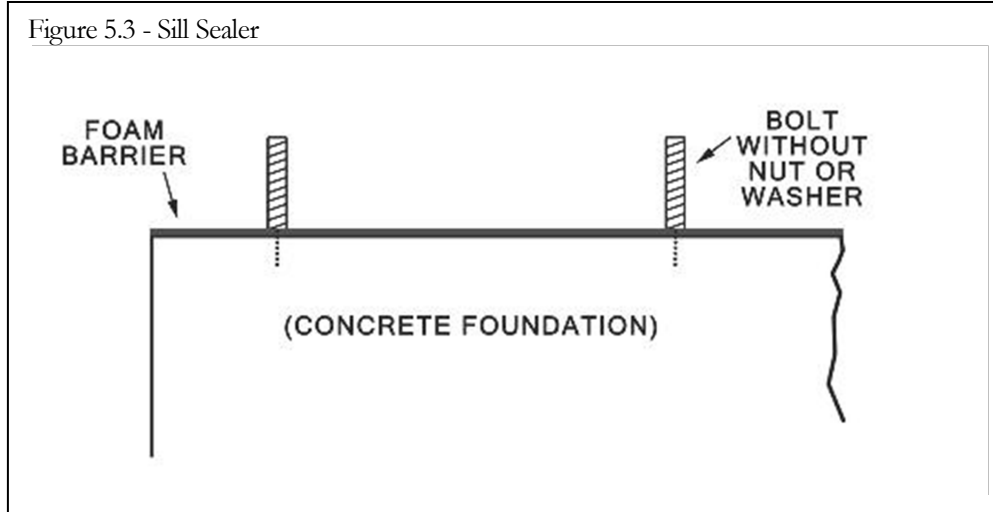

Install the Sill Plates

Critical Issues

- **The sill plates must be installed so they are straight, level, and to the specified dimension of the building.**

1. Apply a bead of silicone caulk to the ends of the sill plates which will be adjacent to another sill plate.
2. Put the Sill Plate in place.
 - Lay the sill plate over the top of the foundation wall, passing the anchor bolts through the sill plate.
 - The anchor bolts may need to be bent to a vertical position to allow the board to pass over them. Take care not to damage the threads during this process. Place the nut on the bolt before striking it with a hammer.
3. Re-install Washer and Nuts to hold the Sill Plate Down.
 - Place the galvanized washers and ½" nut which were saved above on the anchor bolt.
 - Tighten with a long-handled socket wrench until washer sinks into the sill plate.
4. Verify the corners
 - Check each corner by using a 6 – 8 – 10 triangles. (See Figure 5.4).
 - Adjust the sill plates, if needed.

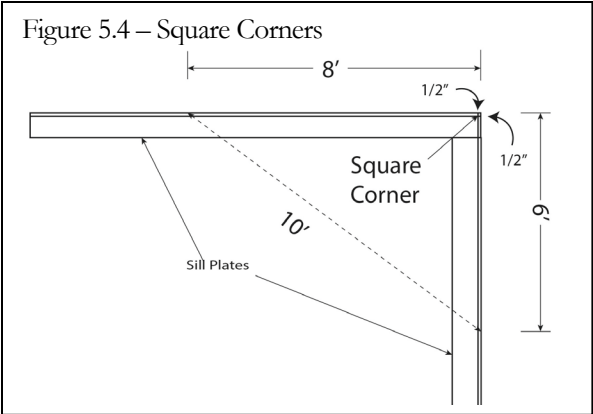

Floor Joists

Figure 5.5 Triforce Joists



The framing of the deck will be built using Triforce open web floor joists. The open web joists allow for spanning the entire building without the need for a center wall.

These joists are trimmable; the last two feet of the OSB panel in each joist can be cut to fit.

Install the floor joists on top of the sill plates (1st floor) or on top of the 2nd top plates (2nd floor). (See Figure 5.6).

Floor Joist System Components

Figure 5.6 – Floor Joist System

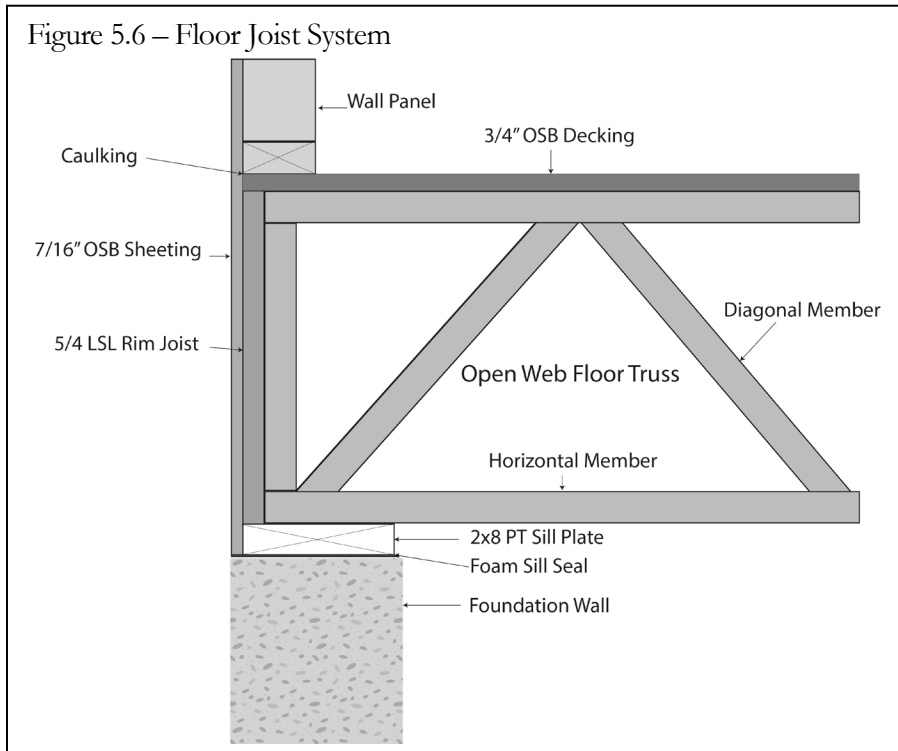

The floor joist system is composed of:

- **Open Web Floor Joist** (16" or 14") – Open-web floor joists are engineered systems of 2x4s; 2x3s and 2x2s which provide a strong structure for the deck.
- **Rim Joist** - 5/4 Laminated Strand Lumber (LSL) - (1 1/8") – The LSL form the rim joist across the ends of the open-web joist. The LSL run perpendicular to the floor joist.
- **7/16" OSB Sheathing** – The OSB sheathing wraps all of the framing. It extends from the foundation wall to the top of the deck framing. OSB sheathing is installed over the LSL Rim Joist and over the exterior sides of the first and last floor joist which sit on the front and back sill plates.
- **3/4" OSB decking** - is installed over the floor joists and cut flush to the outside edge of the joists.
- **LVL's** – Laminated Veneer Lumber are placed under bearing first floor walls.
- **2x6 Strong-backs** – The strong-backs are a series of 2x6s which run continuously from the back to the front of the house. These 2x6s add lateral strength to the system. The 2x6s must overlap to create a continuous run.

Triforce Open Web Joist Design

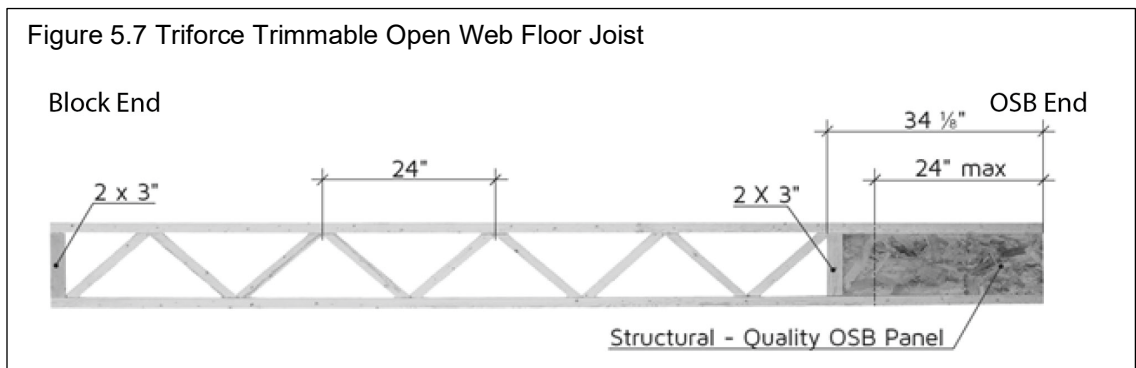

- **Triforce Open Web Joist Features and Benefits**
 - Top and bottom flanges are either 2x3 or 2x4 solid sawn kiln dried chords.
 - Diagonal webs are 2" x 2"
 - OSB End with trimmable OSB panel.
 - Glued finger joints eliminate potential squeaking and eliminate nailing plates.
 - Light weight and easier to handle.

Habitat for Humanity – MidOhio Construction Manual

- Eliminates the need for basement drywall ceilings.
- Triforce Joist Identification
 - Joist are stamped with an identification code:
XX" OJYZZ (ex 16 OJ318) where:
 - XX = Depth (either 14" or 16")
 - OJ – Open Joist
 - Y = Flange (either **3** – 2x3 or **4** – 2x4)
 - ZZ = Grade (14, 15, 18, or 20) **(this is not the length)**
 - Each section of joists on the engineering document will be labeled as J1-n. The joists in each section will have the same identification code and be of the same length. The length is not marked on the joist.

Floor Joists Installation

Critical Issues

- The joists are designed to support the building when they are installed per the engineer's directions.
- Proper layout of the floor Joists is critical to building a square deck for proper support of the structure.
- Ensure the joists are installed with the proper orientation and alignment.
- Install the Triforce joists with trimmable ends all orientated to the same side of the house; per the enclosed documents.
- Floor joists are fragile until they are installed. Be careful not to bend them. It is best to keep them upright as they are carried.
- Keep joists bundled and wrapped until ready to use.
- Do not store joists in direct contact with the ground; 6" off the ground is recommended.
- Do not lift joists by their top flange.
- Check the marking on the Triforce joists to ensure the correct side of each is installed upward.
- LVLs MUST bear at least 2" at each end; including either side of glass block windows, sill plates and bearing walls.
- Trusses and LVLS which land on the foundation of a fire-rated wall should be cut 5/8" shorted. 5/8 Type X drywall will be added to the ends of the trusses.

Safety Issues

- **Joists are large. LVLs are heavy. Many hands are required to handle them properly.**
- **When installing the floor joist, work from inside the building from platform ladders or from exterior scaffolding.**
- **Do not lean over or sit on the walls.**

Review the Floor Joist Engineering Documents

Critical Issues

- The documentation which accompanies the floor joists contains critical information about how the joists were constructed and how the joists are to be installed. Be sure to review this information carefully. This information includes the requirements and location of the strong-backs.

The Engineering Documents identify the specifications for building and installing the floor joist. Review these documents before installing the joists and install per specifications.

Layout the Floor Joists

Critical Issues

- Stairway placement is a critical factor in the framing of the house and their location must be identified before setting the floor joists. Extreme care must be taken to ensure the joists are installed square to the foundation.

1. Review the prints and floor joist plans for:
 - the location of the stairway opening
 - the location of any LVLs (Microlams) which rest on the sill/top plates
 - the starting point for the floor joist layout
 - the spacing for the floor joists (16", 19.2", and 24" o.c.)
 - any floor joist which will be off layout due to plumbing or framing issues.

For the first floor, mark their location on the sill plates. (See Figure 5.8).

For the second floor, mark their location on the second top plates.

2. Mark the sill/top plates with the locations of any of the following which extend over them: (See Figure 5.8).
 - Mark the location of the Stairway on the Plates.
 - Mark the location of LVLs (Microlams).
 - LVLs are available in many sizes, but the most common size will be 1 ¾" wide.
 - Double LVLs are often required under bearing walls.

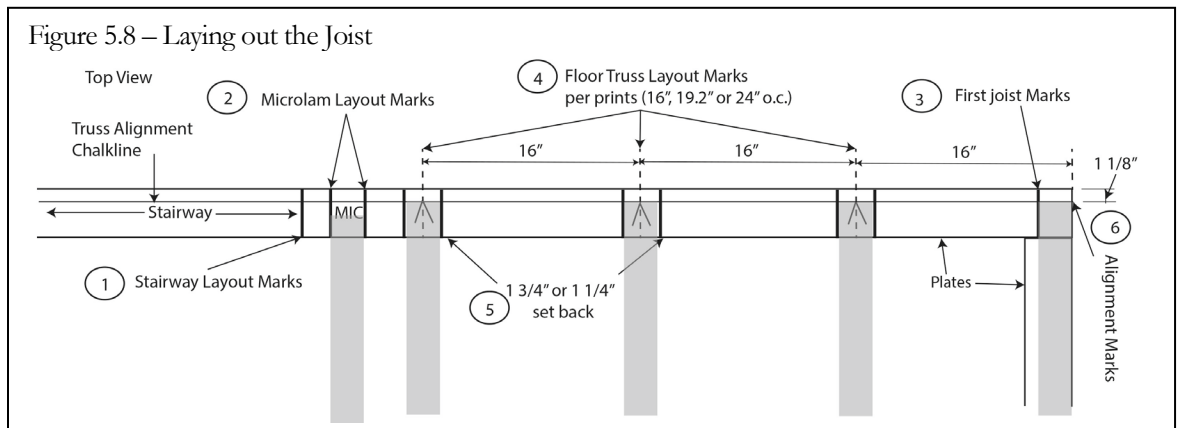

3. Mark the front and back sill/top plates with the first and last joist. (See figure 5.8).
 - Make marks for one joist on each of the front and back sill plates even with the outside edge of the sill plate.
4. Mark the center locations of the Floor Joist on the plates. (See figure 5.8). Ensure the marks are even on both sides of the house.
 - Continuing from the starting points on each side, lay out the floor joist per the spacing on the prints. A few of the joists may need to be moved to allow for stairway headers or plumbing for showers and toilets.
 - Maintaining the proper spacing is critical so the breaks between the decking boards fall in the center of a joist.
5. Mark the joist width set back marks. **Note:** some joists are 2 ½” and others will be 3 ½” wide. Take care to mark the appropriate size for **each** joist. (See figure 5.8).
 - The joists will be installed centered on the layout marks. To assist with their installation, make marks on the plate which indicate where the edge of the joists will sit. Measure back 1 ¾” (for 3 ½” wide joist) or 1 ¼” (for 2 ½” joist) on either side of the center mark.
 - Using a speed square, draw a line across the plates at each mark. This line marks the position of the edge of the joist.
 - **Note:** The floor joists must be installed perpendicular to the sill plates.
6. Mark the side-to-side position of the Floor Joist by creating alignment lines on the sill/top plates. (See figure 5.8). The ends of the floor joists will be set on this line.
 - **Note:** Ensure the two lines are parallel.

- Snap a chalk line across the sill/top plate, 1 1/8" from the outside edges of the sill/top plates at each side of the house.
- Repeat on the other side.

Correct the bolt layout. (1st Floor Only)

1. Move foundation bolts which interfere with the floor Joists or the LVLs by cutting off the foundation bolt and install a Titan anchor in a location between the framing.
 - If the location of any of the floor joist or LVLs falls on top of a foundation bolt, cut off the foundation bolt even with the top of the sill plate. An angle grinder works best.
 - Drill a new hole and install a Titan anchor bolt several inches to either side of the cutoff bolt. Ensure the Titan will fall within the required spacing for anchor bolts.
 - Start the hole with a 5/8" wood spade bit. Then, before drilling completely through the sill plate, use an SDS drill and an 8" long 9/16" masonry drill bit to finish the hole. It is best to remove the sill plate and continue drilling to ensure the hole is deep enough. Clean out the concrete dust from the hole.
 - Insert the bolt and use a large ratchet wrench and a 3/4" socket to drive the Titan anchor down through the sill plate into the foundation.
2. Add missing bolts.
 - If any of the sill plates do not have an anchor bolt installed within 1' of the end of the board, install a Titan anchor as described above.

Install the Floor Joists and LVLs

Safety Issues

- **Working around the open foundation is a hazard.**
- **Do not lean over the foundation wall.**

LVLs

LVLs are used to support greater loads.

Typical locations will include:

- Over basement windows
- Under bearing interior walls
- Single LVLs may be required for headers over stairways and door openings. The plans will indicate the length and location for these.

1. LVLs to support floor trusses landing over **basement windows**
 - a. Typically, a single LVL

- b. For basement window headers, cut the LVL to 42”
- c. The LVL unit will support floor joists so joist hangers must be added. It is best to install them before installing the LVL.
 - i. Center the LVL over the window and mark the location of the intersecting joists.
 - ii. Attach the joist hanger to the LVL unit using N10 Simpson nails. Fill every hole.
- d. The LVL will be installed inside of the Rim Joist.
- e. Position the LVL (1 1/8” from the outside of the sill plate and centered over the window). Then toe-nail in place with two (2) galvanized 16d sinkers on each side on the LVL unit.

2. LVLs to support bearing **interior walls**

Typically, double LVLs are required to support the floor joists.

- Build Double LVLs as required. (see figure 5.9)
 - a. Use two (2) lengths of LVLs. Leave them longer than needed. They will be cut to length after they are assembled.
 - b. Apply construction glue to the adjoining faces of the LVLs.
 - c. Lay the two LVLs together on a flat surface. Hold the top edges of the LVLs even as they are nailed together.
 - d. Nail the LVLs together using 16d sinkers: (see figure 5.9).
 - Two (2) 16d sinkers 3” from each end 2” from the top and bottom.
 - Two (2) rows of 16d sinkers spaced 12” on-center; 2” from the top and bottom; staggered the two rows.
 - e. Cut the assembled unit to fit.
 - **Ensure the unit will be long enough to bear 2” on each end.**
 - At fire-rated walls, leave enough room for 5/8” Type X drywall to be added later.
 - Ensure both ends are square. Trimming both ends maybe required.

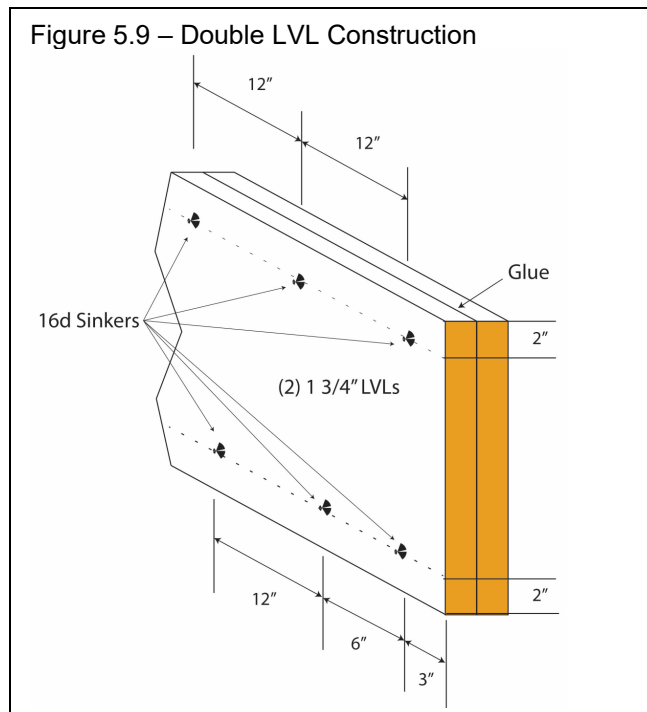

- Install the LVL units
 - a. If the LVL unit will support floor joists, install the joist hangers where needed.
 - i. Mark the location of the intersecting joists.
 - ii. Attach the joist hanger to the LVL unit using N10 Simpson nails. Fill every hole.
 - b. Position the LVL unit and toe nail in place with two (2) galvanized 16d sinkers on each side on the LVL unit.
- 3. LVLs to support floor trusses landing over a **basement door**
 - a. Typically, a single LVL
 - b. Refer to the prints for length and position of the LVL
 - c. The LVL unit will support floor joists so joist hangers must be added. It is best to install them before installing the LVL.
 - i. Put the LVL in place and mark the location of the intersecting joists.
 - ii. Attach the joist hanger to the LVL unit using N10 Simpson nails. Fill every hole.
 - d. Install the LVL and toe-nail in place.

Open Web Joists

Identify and Orientate Each Section of Joists.

- Separate the joists into stacks by the identification code and length.
- Using the identification code, length and count of each stack, label the stacks with their section code (i.e. j1-n) from the engineering document.
- The engineering documents will identify the orientation and location of the joist; location of the strong-backs to be installed; and any special installation instructions.
- The engineering documents picture the joists as they appear from the front of the house.

Floor Joists with Parallel I-Joist Blocking

- The I-Joist blocking will be added to the floor joist at each end of the foundation. It is easiest to install these before installing the floor joist.
- If the I-Joist will be installed to the floor joist before installing the floor joist, lay these joists aside. They will be installed later. (See Parallel I-Joist Blocking below).

Sill to Sill Floor Joists

The joists will sit between the alignment lines made above. (see 5.8).

- Trim the trimmable end of each joist to allow the joist to fit between the lines. (see figure 5.10).
 - Maximum cutoff amount is 24"
 - The top and bottom flanges must be cut to the same length. The flanges must remain within 1/2" of vertical alignment.
 - If either end or both ends land on a sill plate for a first-rated wall, cut the joist shorter to allow the 5/8 Type X drywall to be installed later. (First Floor Only).

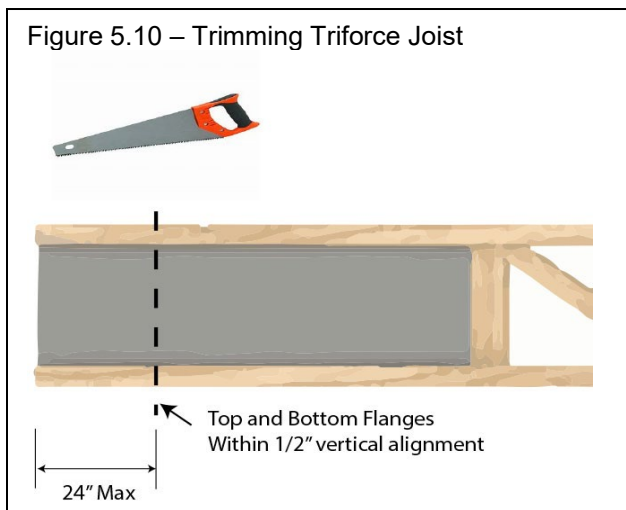

3. Cover Both Sides of the Trimmable End with 5/8" OSB. (First Floor Only).
 - Cut two (2) pieces of 5/8" OSB to fit over the remaining portion of the trimmable panel.
 - Install one piece on each side of the trimmable panel with 1" drywall nails or 1" coarse drywall screws. Insert the screws 2" from the top and 2" bottom of the panel. One set of two screws 2" from the uncut edge of the panel and then at 6" intervals for the remaining of the panel. (see figure 5.11).

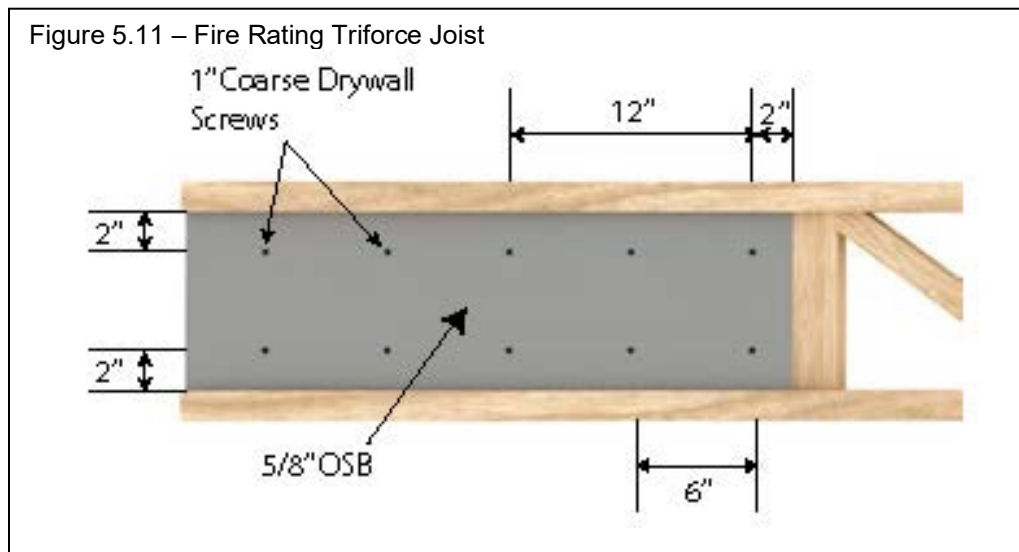

4. Install Each Section of Joists.
 - Starting with the joist at the farthest end of the foundation from where the joists were delivered, install the joists between the layout marks and alignment chalk lines from "Lay out the Floor Joists" above.
 - Set up two platform ladders, one at each side. This will allow volunteers to safely install and attach the joist. Move the ladders along the walls. Do not lean out away from the ladders.
 - Ensure:
 - the joists sit between the layout lines and marks.
 - The trimmable ends of the joists are on the proper side of the house.
 - the joists are cut to the proper length.
 - the horizontal member **marked "BOTTOM"** is facing down. The diagonal members of the joist should be aligned.
 - the top and bottom flanges are within 1/2" of true vertical alignment.

- the joists are bearing at least 2”.
- The trimmable panels of the 1st floor joist have been covered with 5/8 OSB.
- Toe nail the joists in place with:
 - **1st Floor** - two (2) galvanized 8d sinkers on each side of the joist
 - **2nd Floor** - one (1) common 8d sinkers on each side of the joist
 - Note: nails are not placed closer than 2 ½” oc.
- Note: Before finishing each section, determine if the 2x6 strong-backs need to be laid in place now or will it be possible to feed them in later.

Stairway Opening Framing (1st Floor Only)

Construct the Bearing Wall

Critical Issues
<ul style="list-style-type: none">➤ The top of the bearing wall must be level with the top of the sill plates.➤ Bearing walls must be installed over a thickened portion of the basement slab.➤ The length of the studs in the bearing wall must be adjusted to account for the slope in the basement floor.➤ Double studs are required under each floor joist.
Safety Issues
<ul style="list-style-type: none">➤ Hearing protection must be worn when using the ramset tool.

Most house plans will need a bearing wall in the basement to support the floor joists at the stairway.

1. Mark the **Location** of the Bearing Wall.
 - Measure out and mark the width of the stairway opening from the sill plates on the bottom of the floor joist at each end of the opening.
2. Determine the **Height** of the Bearing Wall.
 - Run a string between the marks made above.
 - Measure down from the string to the basement floor. Measure several points along the string as the floor below may not be level.
 - This will be the height of the bearing wall.

3. Determine the Length of the Bearing Wall.
 - The length of the bearing wall will be specified in the prints.

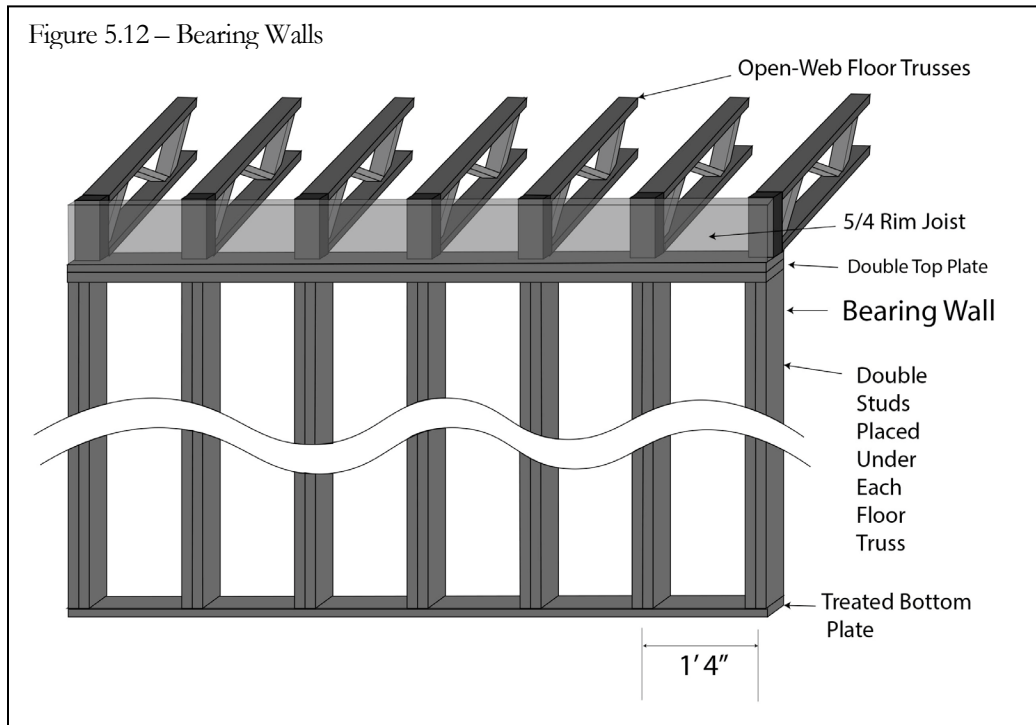

4. Construct the Bearing Walls.
 - Cut the bottom plate using pressure-treated lumber. Cut the two top plates using SPF lumber. Allow for typical overlapping second top plates.
 - Measure and mark the top and bottom plates with the location of the floor joists 16 oc.
 - Nail the wall unit together using galvanized 16d; 2 nails into each stud connected at the bottom plate and 16d sinkers; 2 nails into each stud connected at the first top plate.
 - Cut and position the second top plates to allow for intersecting walls. Attach the second top plate to the first top plate with 16d sinkers; 2 nails into each stud. Insert the nails at an angle so they do not hit the nails below.
5. Install the Bearing Wall.
 - Align the wall with the string from Step 1 above. Do not nail the bottom. The wall will need to be plumbed and nailed down after the floor joists have been installed.

- Install intersecting walls to secure the wall in place. In some cases, temporary supports may be needed.
 - After the floor joists are installed, shim the wall as needed to level the floor joists.
 - Plumb the wall then nail the bottom plate in place using a ramset with 2 ½” nails.
2. Install LVLs for Stairway Opening
 - In some house plans, additional LVLs or LSLs will be needed to frame out the stairway. Add these members per the prints.
 - If the LVL header will be supporting webbed floor joist, add the joist hangers before installing the header. Use the marks on the adjacent top plate to determine the proper locations. Ensure the joists will be flush to the top of the LVL header.
 3. Install the floor joist on the bearing wall
 - Cut and install the floor joist which will be seated on the bearing wall.

Install Parallel Joist Blocking

<i>Critical Issues</i>
<ul style="list-style-type: none">➤ The breaks in the decking must occur over the center of an I-Joist.➤ The I-Joist must be flush to the top of the Floor Truss.
<i>Safety Issues</i>
<ul style="list-style-type: none">➤ Do not stand or sit on the floor trusses while installing the blocking.

1. Parallel joist blocking is installed between the rim joist and the first truss at each end of the foundation. This blocking provides lateral strength to the foundation. Blocking is installed every 24” from the outside of the rim joist. Ensure the decking breaks over the I-Joists.
2. **Use the cut-off ends of the Tri-Force floor joist to build these assemblies.**
3. Cut the I-joist to length specified in the prints, but verify the lengths as described below.
 - At each side of the foundation, measure from the front of the sill plate to the mark for the center of the first truss.
 - Subtract the width of the rim joist and ½ of the width of the first truss.
 - If an OSB mounting block is to be used, cut the I-Joist 1/2” shorter than the opening to allow for the 7/16” OSB.

4. Optional OSB Mounting Block - adding a piece of 7/16" OSB to the end of the I-Joist before connecting it to the floor truss, will make installation of the blocking easier and prevents splitting of the I-Joist.
 - Cut 7/16" OSB pieces 6" - 8" x (height of the Truss – 1/4").
 - Nail the OSB pieces to the end of the I-joist
 - Two (2) 8d sinkers through the OSB into both the top and two (2) into the bottom flange of the I-Joist.
 - Ensure the OSB does not extend above or below the I-Joist.
5. Mark the tops of the trusses with the locations for the parallel joist blocking (mark the centers). It is important the marks are 24" OC from the outside of the rim joist so the breaks in the decking will fall over the I-Joist.

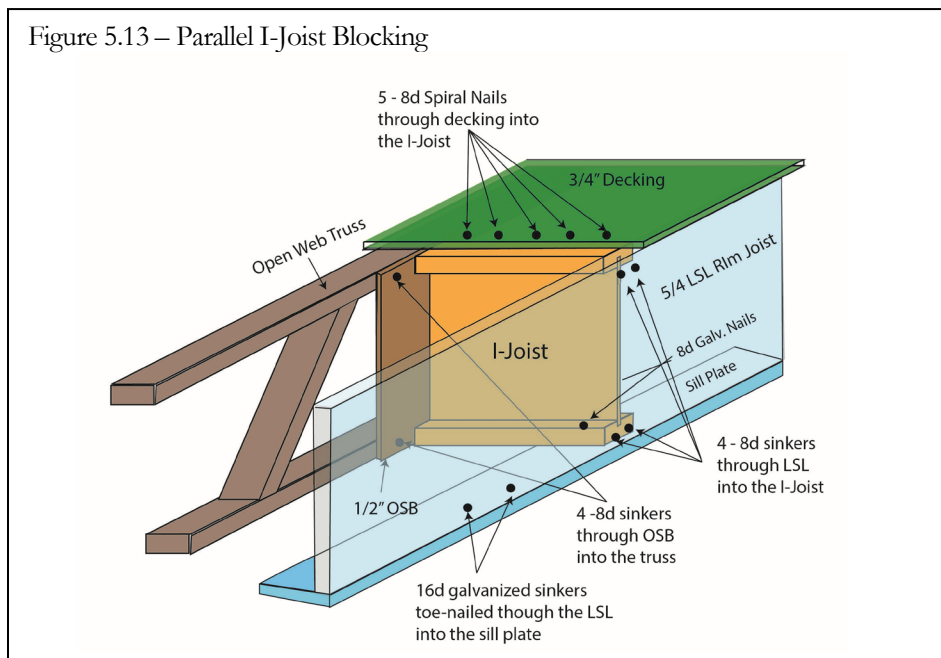

6. Install an I-Joist assembly at each line. (See Figure 5.13).
 - The I-Joist blocking can be installed before or after installing the floor joist to which they will be attached.
- Before:
- Lay the floor joist on a solid surface with the side which will face the I-joist facing up.
 - For blocking with OSB mounting blocks, attach them to the trusses; two (2) 8d sinkers through the OSB into the top chord and two (2) 8d sinkers into the bottom chord.

- For blocking without OSB mounting blocks, toe-nail them to the trusses with two (2) 8d sinkers through the top chord and two (2) 8d sinkers into the bottom chord.
- Carefully place the floor joist on the foundation so as to not dislodge the I-Joist blocking.
- Hold the I-Joist blocking perpendicular to the floor joist and nail it to the sill/top plate with two (2) 8d sinkers through the bottom chord into the plate.

After:

- Two (2) volunteers will be required to install each assembly. One volunteer will need to work from outside and one volunteer on a platform ladder below.
 - Attach the OSB mounting blocks to the trusses; two (2) 8d sinkers through the OSB into each top chord and two (2) 8d sinkers into each bottom chord.
 - A palm nailer should be used as there is little room to swing a hammer.
 - Toe-nail the I-Joist to the plate below with 8d galvanized nails (1st Floor) or 8d sinkers (2nd floor); two (2) nails through each edge of the I-Joist into the plate below.
7. When installing the decking, nail the decking to the parallel I-Joist blocking with five (5) 2 3/8" framing nails through the decking into the top of each I-joist.

Strong-backs

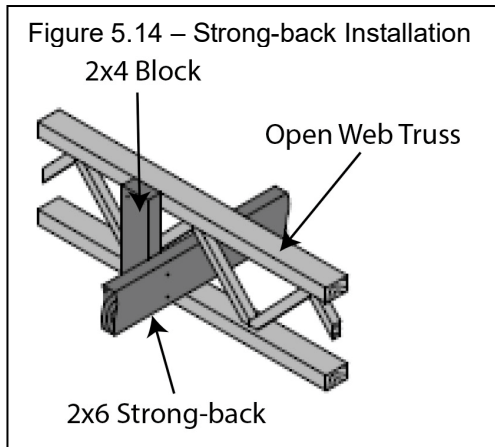

Once all joists for a section have been installed, install 2x6 strong-backs at the mid-point of the webbing. The strong-backs will connect the joists together.

There must be one continuous set of strong-backs extending from the front to the rear of the house connecting all the joists together.

Install the Strong-backs

Critical Issues

- **Ensure the strong-backs are installed such that the joists are tied together from the front to the back of the house.**

Safety Issues

- **If using a framing nailer to install the strong-backs, ensure there are no volunteers behind the strong-back when it is being nailed.**

- Cut 2x6s to be used as strong-backs. The strong-backs must extend from the front of the house to the back of the house with a 32" overlap between pieces except when they are separated by an LVL.
- Cut 2x4 blocks to a length of the height of the joist. Cut one block for each joist.
- Feed the 2x6 strong-backs through the center span opening of the joists.
- Secure the 2x4 blocks vertically to the side of the joists with two (2) 3 1/4" framing nails through the block into both the top and bottom flanges.
- Secure the 2x6 strong-back to the 2x4 blocks with two (2) 3 1/4" framing nails.
- When the section of joists is longer than the 2x6s, 2 or more pieces of 2x6 will be needed. The 2x6s must overlapped by at least 32" and one joist bay. Secure the overlapping pieces with rows of three (3) 3 1/4" nails at 4" oc. (see figure 5.22).

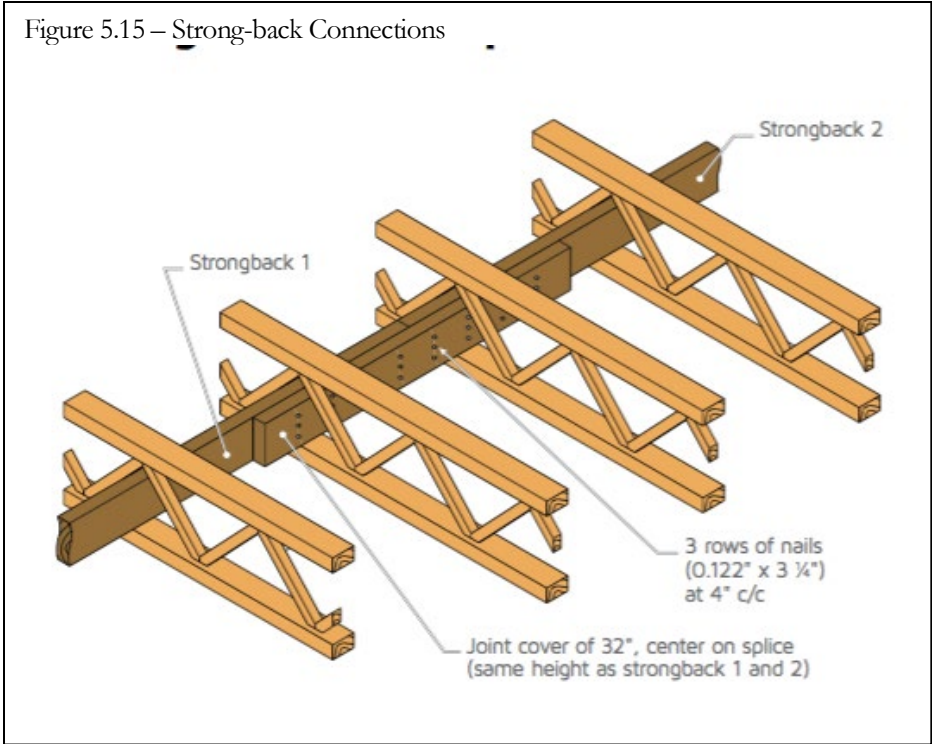

Install Type X Fire-Rated Drywall (1st Floor Deck only)

Before installing the Rim Joist along walls which must have fire rating protection, install the fire-rated drywall in one continuous piece between the floor joists and the rim joist. This will be easier and less cumbersome than cutting individual pieces for each joist bay later.

Install the Rim Joists (Band Board)

Critical Issues

- Ensure the rim joists stay plumb when they are being installed.
- Do not remove hanging scaffolding to install the rim joists on the 2nd floor. The rim joist must be notched to fit over the clamps.

Figure 5.16 – Rim Joist



The rim joist will be attached to the ends of the floor joists to support the deck.

1. Cut pieces of 5/4 LSL to fit across the ends of the joists. If the piece of LSL will not span the entire end, cut the pieces to lengths that will join at the center of a joist.
2. If the rim joist will fit over a hanging scaffolding clamp, cut a 4"x 3" notch in the rim joist at the location of the clamp. This will allow for the removal of the scaffolding clamp later.
3. The rim joists sit flush to the outside edges of the sill plates and extend to the outside edge of the front and back sill/top plates.
4. Apply silicone caulk to the top of the sill plate, 3/4" from the outside edge. Caulk should be applied just before the rim joist is set in place.
5. Place the LSL rim joists flush with the edge of the front or back sill/top plate and tight to the ends of the joists.
6. Toe-nail the rim joist to the sill plate with 16d galvanized nails (1st floor) or 16d sinkers (2nd floor); 1 nail every 16".

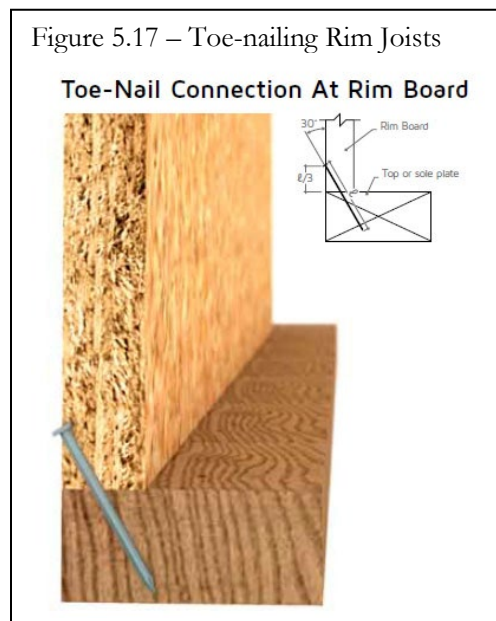

7. Plumb the floor joists then nail the rim joists to the floor joist with 8d sinkers; 1 nail through the LSL into the top flange of the floor joist and 1 nail through the LSL into the bottom flange of the floor joist. **Be sure the joist and rim joist are plumb.**

Post King/Jacks to the Sill/Top Plate

The load from Load Bearing Members above the deck, such as King/Jack pairs, must be carried to the sill below. (see figure 5.18).

1. Mark the location of the king/jack pairs for the windows and exterior doors on the rim joists. If the king/jack will not fall over a floor joist, add blocking to carry the load.
 - a. Cut a (2) two 2x4s to the length of the rim joist for each king/jack pair.
 - b. Install the 2x4s with their wide side towards the rim joist and attach with 2 1/2" screws.

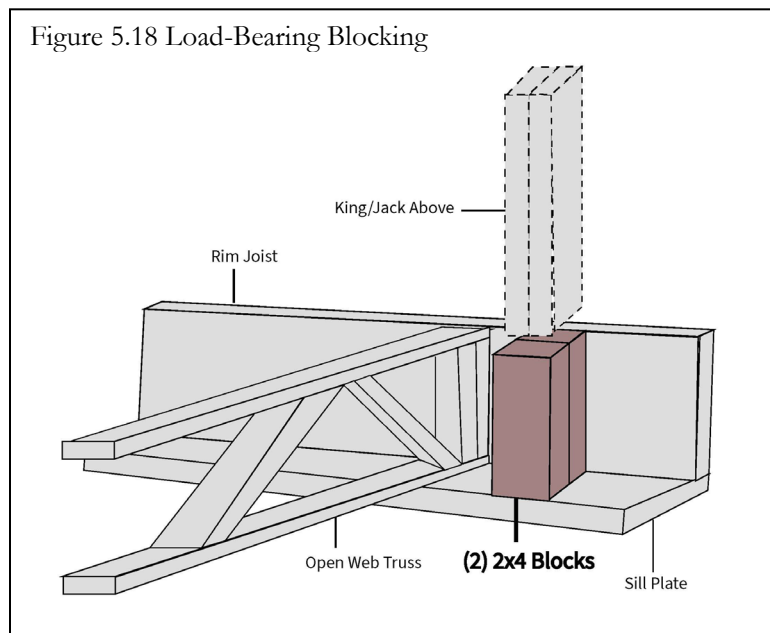

Mounting board for Water Manifold

The plumbing subcontractors will need a 4x8 sheet of 3/4" OSB in the basement for mounting the water manifold. Often moving this board to the basement after the stairs have been installed is impossible; therefore, it is a good idea to store this in the basement before installing the decking.

Be sure to place blocking under the board and cover it to keep it dry.



Before continuing, stop and complete the “**Pre Decking Checklist**” found in Procore/Inspections.

Decking

<i>Critical Issues</i>
➤ 1/8" gaps must be maintained between all edges of the decking boards.
<i>Safety Issues</i>
➤ A Guardrail system must be installed around stairway openings as soon as possible.
➤ For second floor decks, guardrail or hanging scaffolding systems must be in place around all exterior edges.
➤ It is important that the decking does not extend into the stairway opening without proper supporting framing.

Setup Fall Protection

Planning is required to provide adequate fall protection.

1. Develop the "Fall Protection Plan"
Safety Gear will include:
 - Hanging Scaffolding (long sides of 2nd floor decks)
 - Guardrails (all sides of the openings and short sides of 2nd floor decks)
 - Control Zones
2. Ensure Hanging Scaffolding is in place where needed.

Lay out the Decking

1. Lay out and Mark the Floor Joists for the Decking. (See Figure 5.26).
 - The decking will be installed perpendicular to the floor Joists.

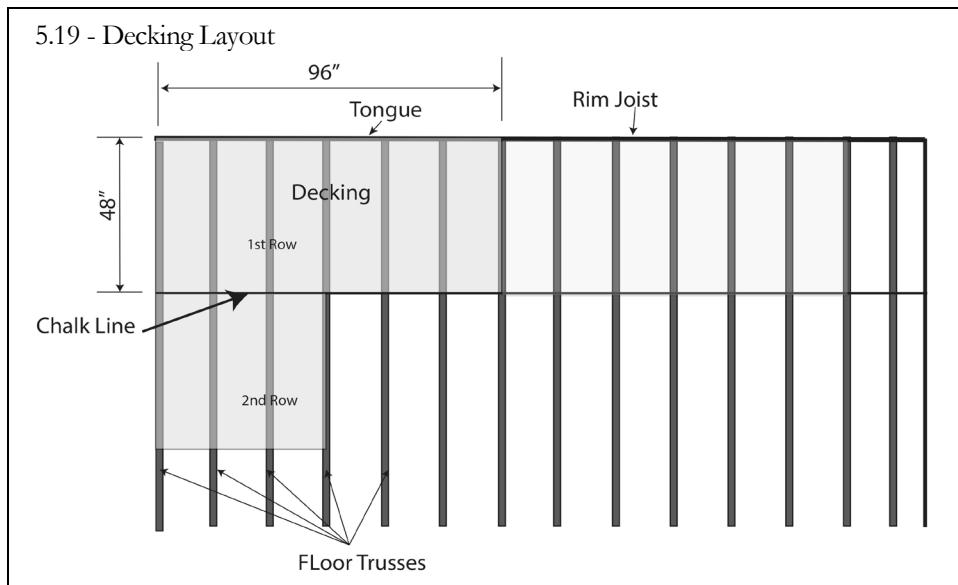

2. Snap chalk lines across the tops of the floor Joists to provide a line to align the decking. Beginning from the same corner from which the floor Joists were started, mark both the front and back joists 48" from the corner of the same side of the house. Then snap a line across those marks.
 - The OSB sheets are only 47 ½" wide. Setting them at 48" from the edge will leave ½" of the rim joist exposed. This will eliminate the need to cut the decking due to irregularities in the framing.
3. Mark the ends of the floor joists where the decking breaks will occur.
 - Verify the breaks between the decking will fall over a floor joist. The decking may need to be cut to fit.
 - Verify all sheets of decking will be supported by at least three (3) floor joists.

Install the Decking

First row of decking

1. Determine where the breaks between the sheets of OSB will occur.
 - Use as many full sheets as possible.
 - Ideally, the cutoff for the end of the first row will be used to start the 2nd row.
2. Apply a wide bead of construction adhesive to the top of floor Joists in an area from the chalk line to the rim joists for the first 7 floor Joists. Also, apply adhesive to the rim joist in this area.
 - Apply the adhesive using a long handle caulking gun. Do not walk out on the floor joist to install the adhesive.
3. Set the ¾" OSB decking in place.

The first row of decking on the 1st floor can be set in place while standing on the ground. The first row of decking on the 2nd floor will be installed from the scaffolding. The decking will be handed up below the guardrails.

Slide the decking in place. A worker on a platform ladder positioned below will be required to align the decking to the chalk line.

- On some OSB, one side will be stamped “**This side down**”; make sure they are installed accordingly with that side down. On others, one side will have layout numbers stamped on them; make sure they are installed with that side up.
 - Install the sheets with the tongue extended over the rim joist.
 - Align the grooved edge of the sheets with the chalk line with the short edges breaking over the floor joists.
 - The short edges of the decking (non-tongue and grooved edges) must land in the middle of a joist or over the rim joist.
 - Maintain a 1/8” gap between the sheets.
4. Nail the OSB down with a framing nailer using 2-3/8 in x .113 in nails; 1 nail every 6” around the perimeter and every 8” into the joists in the field.
 - Nail down the tongue edge first.
 - Pull the floor joist into line with the decking and then nail down the grooved side. Make sure not to nail within 3/4” of the edge because this will close the groove making it difficult to install the next sheet.
 5. Once the tongue and groove edges are all tacked in place, install nails 8” apart across each joist and 6” apart along the rim joist.

Second and Remaining Rows of Decking

1. Apply adhesive to the top of the floor joist using a long handle caulking gun. Only cover the next 48”. If adhesive extends beyond the area to be covered by the next row of decking, remove it quickly.
2. Place the next row of decking inserting the tongues of the new sheets into the grooves of the previously installed sheets.
 - Placing the following rows of decking will require a couple of volunteers who are wearing harnesses.
 - Ensure the decking is installed with the correct side facing up.
 - Stagger the breaks between the sheets on alternating rows.
 - A small amount of pressure may be needed to align the decking to allow the tongues of the new sheet of decking to seat into the groove to the previously installed sheet of decking. Do not drive the sheets into place. A 1/8” gap must be maintained between the sheets.

3. Measure and cut to fit any decking sheets which will extend into the stairway openings or over the edges of the deck. Ensure the decking does not extend over the edges. Nail down the decking repeating the procedure from the first row.

Safety Activities

Temporary Stairs (1st Floor Only)

Build Temporary Stairs for Accessing the Deck

Before work can begin on the deck, two sets of temporary stairs must be installed; one leading up to each porch. These stairs will be suspended from the foundation walls of the porch. (See Figure 5.20).

The stairs will need to be removed when the porch cement cap is poured. The steps must be modified and re-installed immediately before continuing with framing.

Critical Issues

- ***A good understanding of stair construction is recommended.***
- **The ground under the bottom plate must be level and solid.**

Safety Issues

- **Handrails must be constructed on both sides of the temporary stairs.**
- **The height of the top rail of each handrail must not be more than 37" from the nose of the treads and not less than 34".**
- **The mid rail of each handrail must be midway between the top rail and the nose of the treads.**
- **The hand railings must be able to withstand 200lb of lateral force.**
- **The stair treads must be spaced out with an equal amount of rise for each step.**
- **The stairs must be staked to the ground and anchored to the foundation.**

6. Calculate the number of **rises**.
 - Measure the distance from the grade to the top of the foundation wall.
 - Divide the distance by 8. Round down to the next lower number. That will be the number of rises.
7. Calculate the height to the **rise**.
 - Divide the distance from the grade to the top of the foundation by the number of rises. This will be the height of the rises.

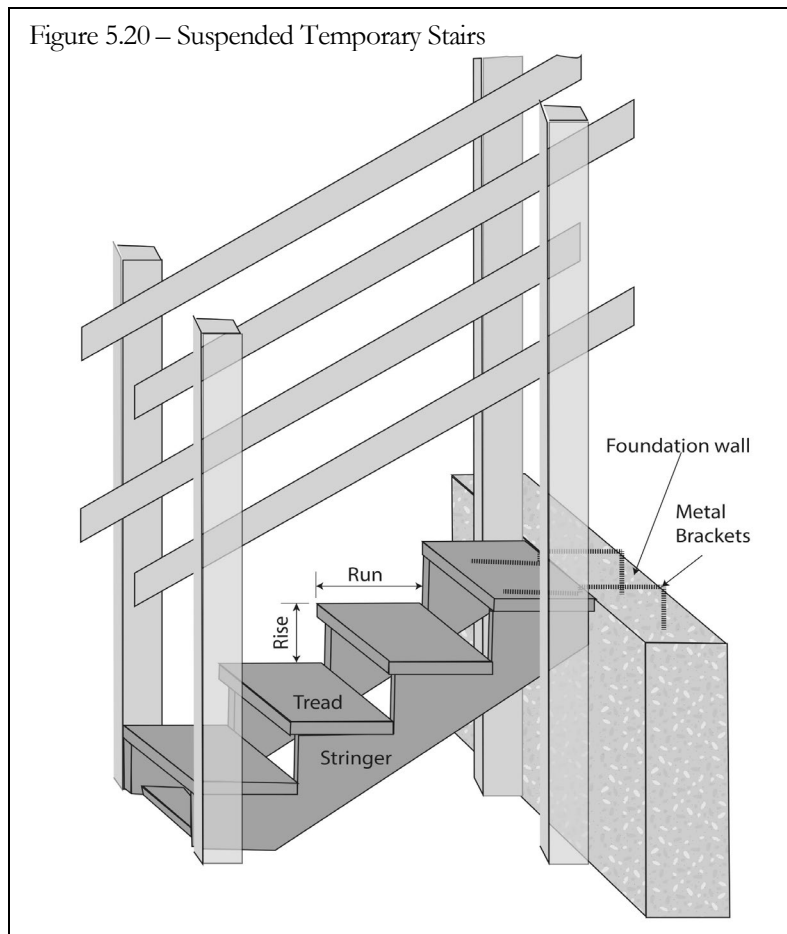

8. Create Layout lines on the stringers.
 - a. On a framing square, mark the **rise** and the **run**. The rise (calculate above) will be marked on the short leg. The run (9" – width of the 2x10 treads) will be marked on the long leg.
 - b. Mark the first set of layout lines by holding the rise and run marks to the edge of the 2x12 stringer, then trace the layout lines along the edges of the framing square. (See Figure 5.22).
 - c. Continue marking layout lines by moving the framing square along the edge of the board until the rise mark is aligned to the previous run mark.
9. Mark the bottom cut line. The bottom rise will be 1 ½" shorter, so the bottom cut line will be parallel to and 1 ½" above the bottom "run" layout line.
10. Mark the top cut line. The top of the stringer will be cut off by extending the first rise cut down perpendicular to the first tread.
11. Repeat these marks on the second 2x12 stringer.

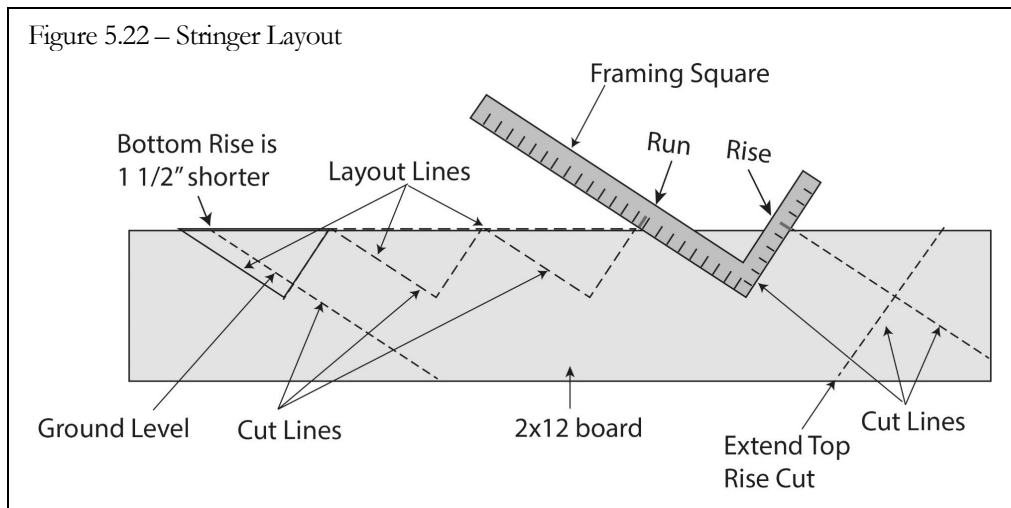

The website <http://www.blocklayer.com/Stairs/Stairs/Eng.aspx> can provide more information and calculations needed for this process.

12. Cut the stringers.
 - a. Cut out the stringers at the layout lines made with the framing square. Do not cut into the stringer. Finish the cuts with a hand saw.
 - b. Cut along the bottom and top cut lines.
13. Count the number of treads needed and cut the 2x10x36" treads.
14. Cut a 2x8x33" bottom support. Adding a bottom support will keep the stairs from sinking in the mud. This support will fit inside the stringers, so it will need to be 3" shorter than the treads.
15. Assemble the stairs.
 - a. Screw the 2x10 treads to the stringers. Hold the stringers upright. Place the treads in place. Hold the ends of the treads flush to the outside of the stringer. Screw the treads in place using 2 1/2" #10 exterior screws; 3 screws through each end of the tread into the stringer below.
 - b. Screw the 2x8 bottom plate to the bottom of the stringers. Turn the stairs upside down. Place the bottom plate in between the stringers flush with the bottom of the stringers. Screw the bottom plate in place using 2 1/2" #10 exterior screws; 2 screws through each stringer into the ends of the bottom plate.
16. Add Support Brackets. (See Figure 5.23).
 - a. Attach two (2) metal brackets to the underside of the top tread with two (2) 3/8"x4" carriage bolts through each bracket.
 - b. These brackets will hook over the porch wall to hold the steps in place until the porch cap is poured.

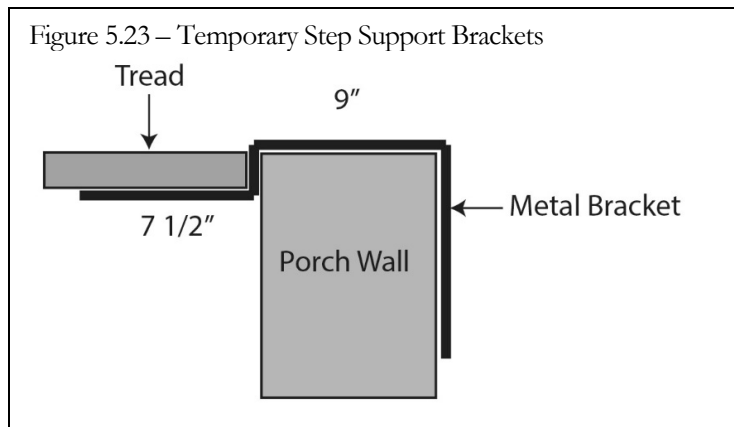

17. Install 2x4 handrail Posts. (See Figure 5.24).
 - Cut two (2) 2x4x88" handrail posts and attach to the outside of the stringers; 1 handrail post on each side at the top of the stairs. Set the bottom of the posts even with the ground and attach to the stringers with 2 1/2" exterior screws; 3 screws through the handrail post into the stringer.
 - Cut two (2) 2x4x52" handrail posts and attach to the outside of the stringers; 1 handrail post on each side at the bottom of the stairs. Set the bottom of the posts even with the bottom on the stringer and attach with 2 1/2" exterior screws; 3 screws through the handrail post into the stringer.
18. Install 2x4 handrails to the handrail posts. (See Figure 5.24).
 - Cut four (4) 2x4 handrails; 2 for each side. Plumb cut the ends.
 - Attach the handrails to the handrail posts with 2 1/2" exterior wood screws; 2 screws through each end of the handrail.
 - Top of top rail must not be more than 37" above the nose of the treads. A height of 36" above the treads is recommended.
 - Mid-rail must be midway between the top rail and the nose of the treads.
19. Add shingles to the treads. Nail one shingle to each tread with 1 1/2" roofing nails.
20. Stake down the front and rear handrail posts with a 12" 2x4 stake.
 - Cut four (4) 12" 2x4 with a pointed end.
 - Drive the stakes in the ground next to the front and rear handrail posts.
 - Attach the stakes to the handrail posts with 2 1/2" exterior wood screws; 2 screws through the stake into the handrails.

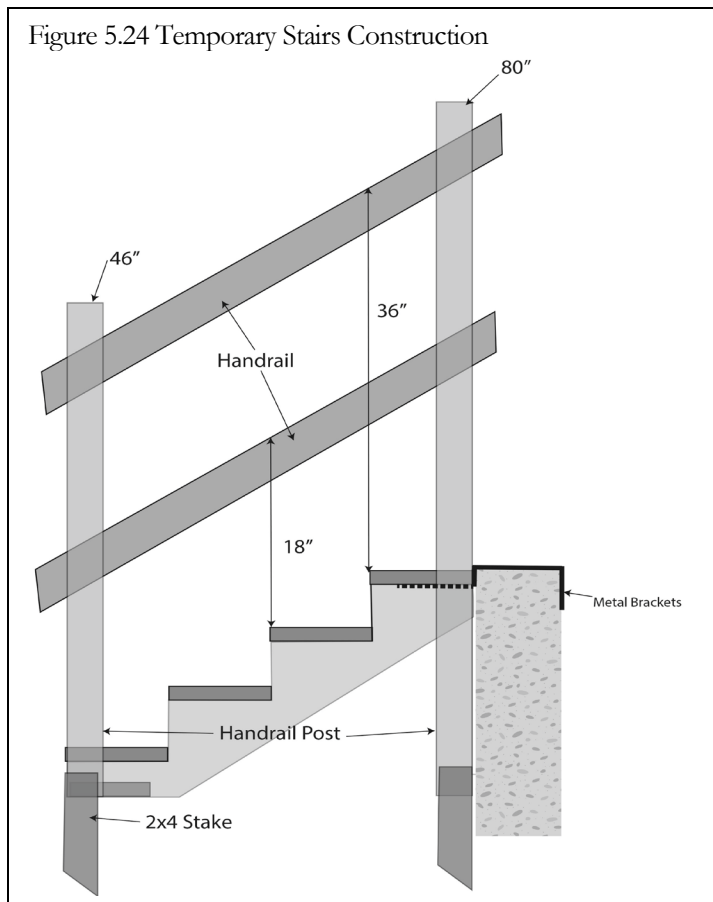

Guardrails

Critical Issues

- Guardrails must be installed prior to decking to protect the volunteers during construction.

Safety Issues

- Guardrails must be constructed on all sides of the stairway opening.
- The top rail must be 42" from the deck.
- The mid rail must be 21" from the deck.
- A toe board must be installed at the bottom.
- The guard railings must be able to withstand 200lb of lateral force.

Install Guardrail Posts at Stairways

Install 2x4 Guardrail posts in each corner of the stairway opening and at the midpoint on walls over 6'. The posts will be anchored into the floor joists or LVLs. If possible, the posts on the same side of the opening should be installed at 90-degree angles. (See Figure 5.25).

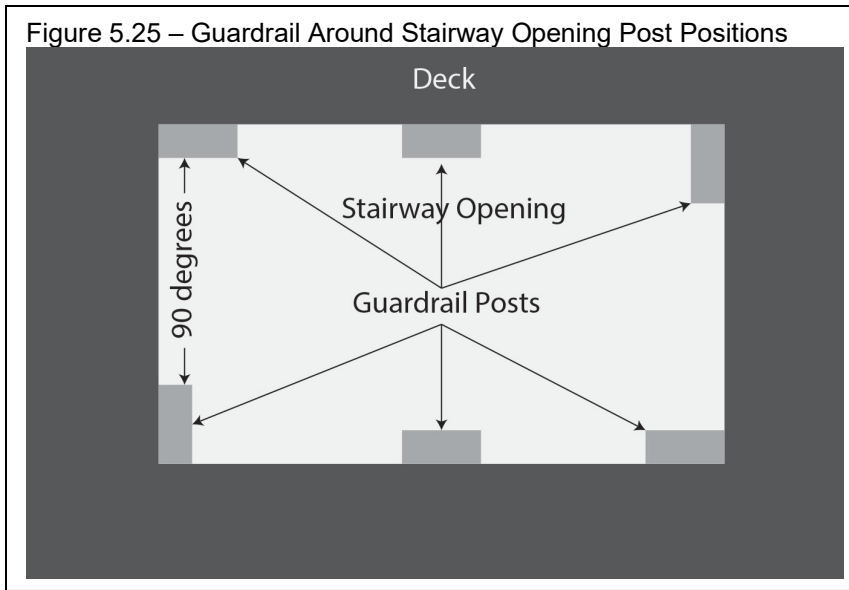

1. Cut 2x4 pieces which are approximately 60" long to build each guardrail post. Each post must extend at least 42" above the deck and to the bottom of the floor joist.
 8. Screw posts to the deck using 3 1/2" screws; 2 screws extended through the post into the top member of the joist or the top of the LVL and 2 screws through the post into the bottom member or bottom of the LVL. (See Figure 5.26).

Figure 5.26 – Guard Rails Post Attachment

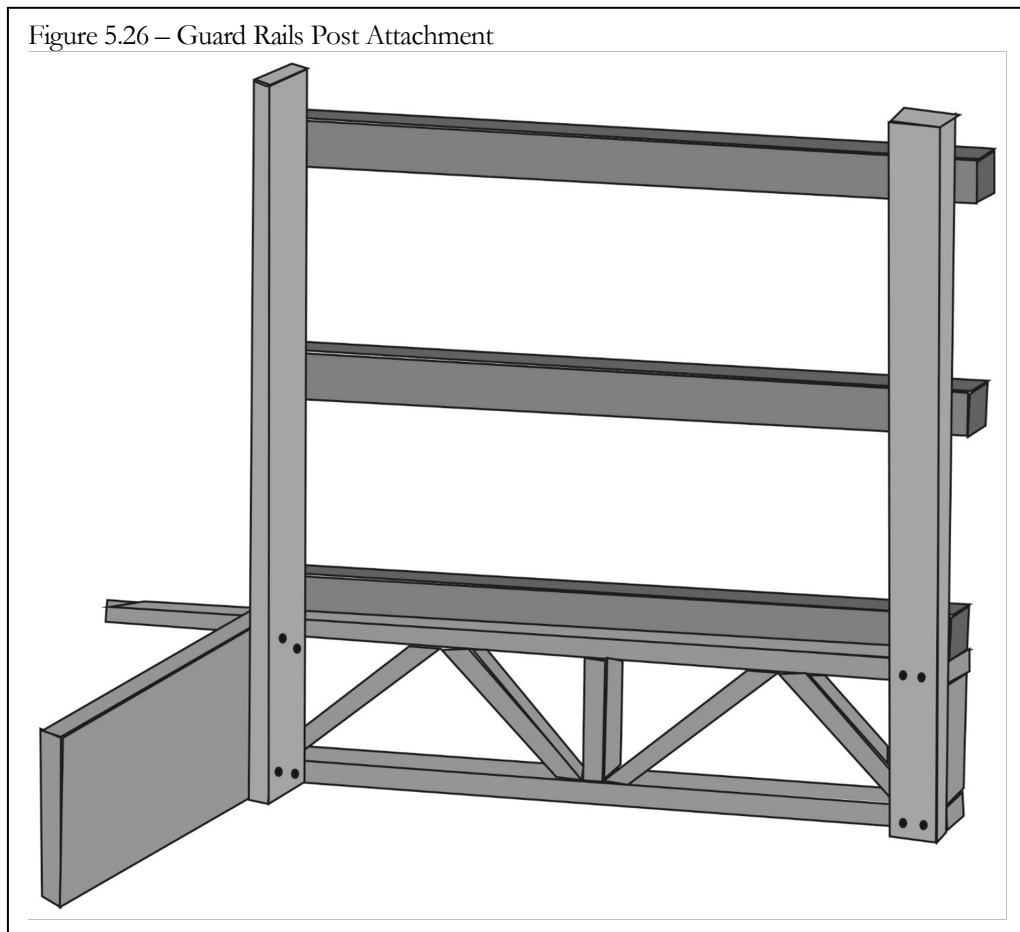

Install Guardrail Posts on Edge of the Deck

For second floor decks, additional guardrails will be needed along the front and back edges of the deck. The sides should be protected with hanging scaffolding.

- Add guardrail posts at the corners and every 6' across the front and back of the deck; similar to the guardrail posts installed around the stairway openings.

Install Guard Railings and Toe boards

- Two (2) 2x4 guardrails will be attached to the Guardrail Post across each opening. The distance from the deck to the top of the top railings must be 42" and 21" to the top of the mid rail. A 2x4 toe board will also run across the opening at the floor level. (See Figure 5.27).
- The rails will overlap at the corners, with the railing running over the 3 ½" side of the post cut even with the post; and the railing running over the 1 ½" side of the post, extending to the front of the first railing.
- Attach the railing and toe board to the post with 2 ½" screws. (See Figure 5.27).

- Attach the railing and toe board to the 3 ½" side with 3 screws in a triangular pattern.
- Attach the railing and toe board to the 1 ½" side with 4 screws; 2 into the post and 2 into the crossing railing.

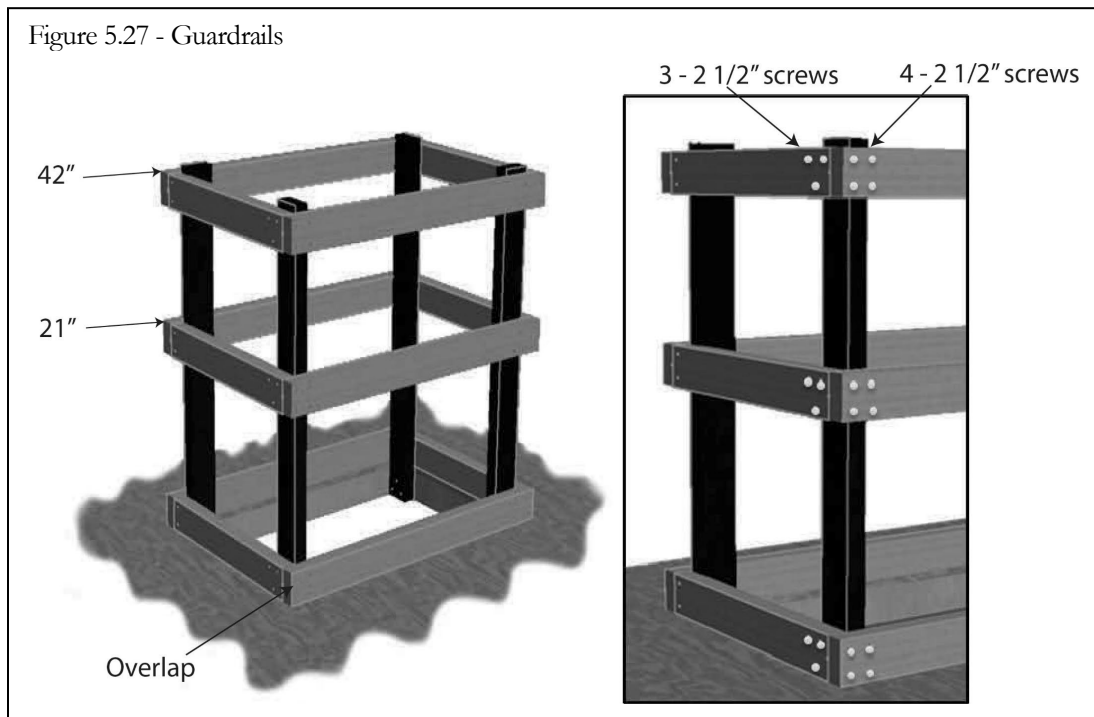

Hanging Wall Scaffolding System (2nd Floor Only)

Critical Issues

- Hanging wall scaffolding will be required on all two-story houses.

Safety Issues

- The failure to understand and comply with safety regulations may result in serious injury or death.
- Scaffolding brackets must be installed from a securely anchored extension ladder.
- Inspect all components of the scaffolding system each day before its use.
- No more than 2 volunteers on a section at a time.
- Never climb or lean on the Stacker Bracket System

Hanging Wall Scaffolding Systems

Habitat for Humanity MidOhio uses 2 different hanging wall scaffolding systems:

- 1) Stacker Bracket Frame System
- 2) Wall Walker System

Consult the manufactures directions for installation of these systems.

Hanging Wall Scaffolding Use and Timing

1) Second Floor Deck

Before installing the 2nd floor joists and decking, install the hanging wall scaffolding. Install scaffolding on the tops of the 1st floor walls along the long sides of the house. This will provide a safe working platform and safety railings around the deck for:

- nailing off the floor joist
- installing rim joists
- Installing decking.

2) Second Floor Exterior Walls

The scaffolding installed for the 2nd floor deck will be left in place during the installation of the 2nd floor exterior walls. This will provide a safe working platform and safety railings for building, positioning and installing the walls. The scaffolding must be removed before filling in the OSB sheathing and installing the Styrofoam insulation.

3) Roof Joists

The “Wall Walker” system can be used for installation of the roof joists and sub-fascia. The Stacker Bracket system cannot be used since it cannot be adjusted down the wall for clearance from the joist tails.

Set up the “Wall Walker” system on the top of the 2nd floor walls only on the sides of the house which will have joist tails. This will provide a safe working platform and provide guardrails for nailing off the joists and installing the sub-fascia.

Install Styrofoam Board behind Porch Concrete (1st Floor only)

Critical Issues

- **A water plane and thermal break are required between the floor joists and the porch concrete.**

- 1) After the ½” OSB sheathing has been added to the outside edges of the deck, add 1” Styrofoam board behind the porch areas. Extend the Styrofoam board from the top of the deck down to the top of the 2” Styrofoam on the basement walls.
- 2) Cut pieces of 1” Styrofoam board to a width equal to the distance from the top of the foundation Styrofoam to the top of the deck. Cut to a length which will extend 2” or 3” beyond the location of the deck, but not past the edge of the house.
- 3) Attach the 1” Styrofoam board to the OSB sheathing using 3” cap nails; 2 nails every 16”.



Before continuing, stop and complete the “**Post Decking Checklist**” found in Procore/Inspections.

Concrete Porch Caps (Contractor)

Once the deck framing is complete, the contractors will form-up and pour the porch caps. The porch cap is the 4” concrete porch deck poured over the porch foundation.

Before the caps are poured:

- Remove the temporary stairs which are suspended on the porch foundation.
- Ensure the 1” Styrofoam has been installed to the framing behind the area where the porch caps will be poured.

After the caps are poured:

- Re-install the temporary stairs. (See “Re-Install the Temporary Stairs after the Porch Cap is poured” below).
- For three (3) days after the concrete is poured, cover the traffic areas on the porches with pieces of OSB.

Re-Install the Temporary Stairs after the Porch Cap is poured

The temporary steps built above will be removed to pour the porch cap. The steps can be reused by removing the metal brackets and adding a ledger. (See Figure 5.28).

1. Add a 36" 2x4 ledger to the concrete forms used to pour the porch cap. The ledger will be added 1 ½" below the bottom of the cap. Attach the ledger with 2 ½" #10 exterior screws.
 - Remove the metal brackets from the bottom of the top tread.
 - Slide the steps into place with the top tread sitting on the ledger.
 - Level the ground below the bottom support to keep the treads level.
 - Attach the top tread to the ledger with 2 ½" #10 exterior screws.

